

Boletim **Técnico**

037 - Julho 2025

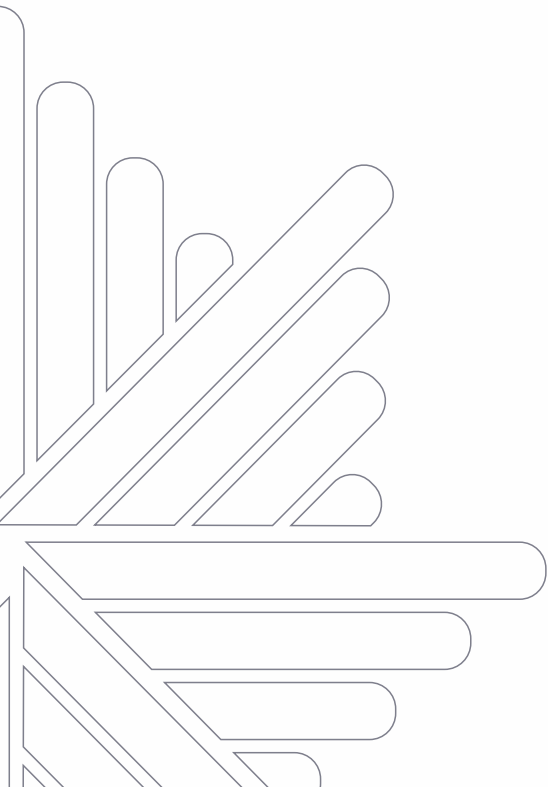





Boletim Técnico

Informações gerais

- O boletim técnico é um documento desenvolvido pelo setor de engenharia da Aludim Alumínio Ltda e informa sobre o desenvolvimento de novos perfis e as alterações no portfólio dos produtos, modificando ou complementando os catálogos.
- Este boletim deve ser consultado frequentemente, antes do levantamento de projetos ou de pedidos, pois detalhes contidos nos catálogos são atualizados periodicamente.
- Informações contidas no boletim técnico podem ser alteradas sem aviso prévio. Consulte ou solicite as versões atualizadas dos catálogos e boletins no site www.aludim.com.br ou entre em contato através do telefone (48) 3626-4900 ou pelo e-mail engenharia@fretta.com.br.



Boletim Técnico

Índice

Novos Perfis Linha Enseada Tabelados

pág **05**

Novos perfis Sistemas de Esquadrias
Jurerê 32

pág **06**

Novos Perfis Sistemas de
Esquadrias Itapema

pág **07**

Alteração de Perfis Sistemas de
Esquadrias Itapema

pág **08**



Boletim Técnico

Novo Perfil

Tubo Redondo

TR-100 1,289 kg/m

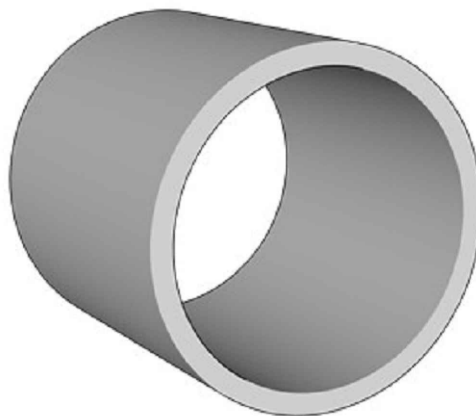
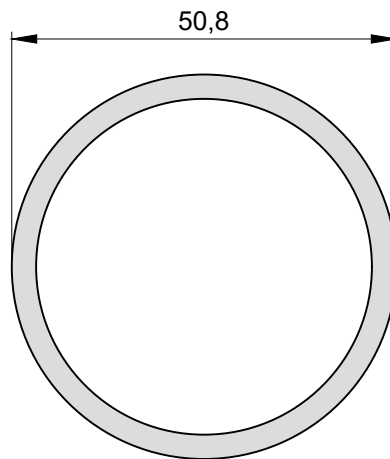

TABELADOS LINHA ENSEADA



Boletim Técnico

Novo Perfil

Folha Porta de Giro

LG-042 1,170 kg/m

Folha Porta de Giro

LG-042 1,170 kg/m

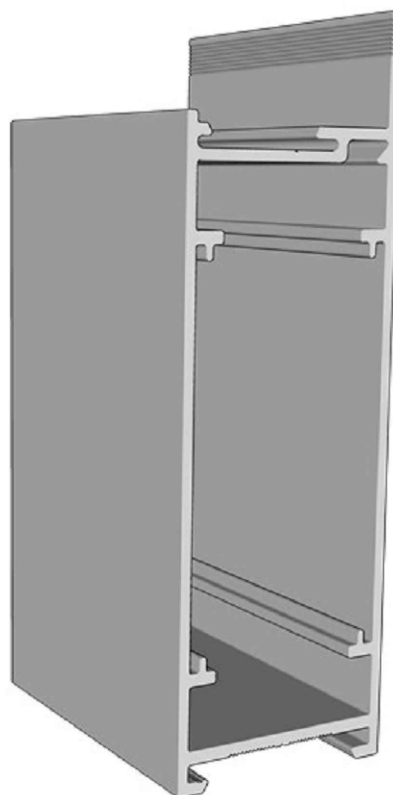
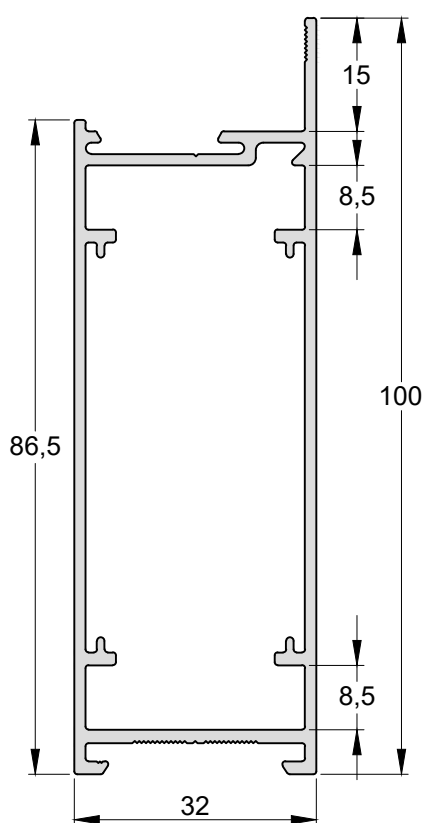



Boletim Técnico

Novo Perfil

Coluna Central	
AD-354	1,317 kg/m

Coluna Central	
AD-354	1,317 kg/m

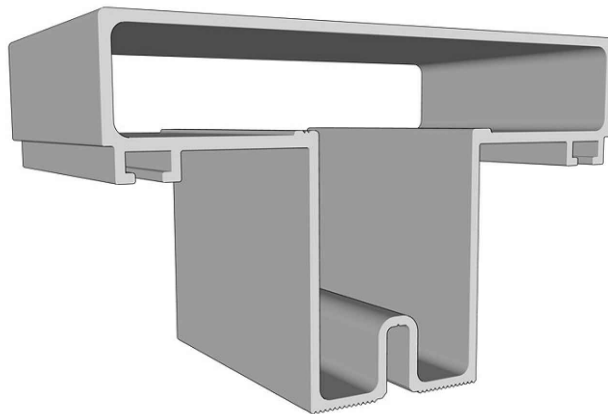
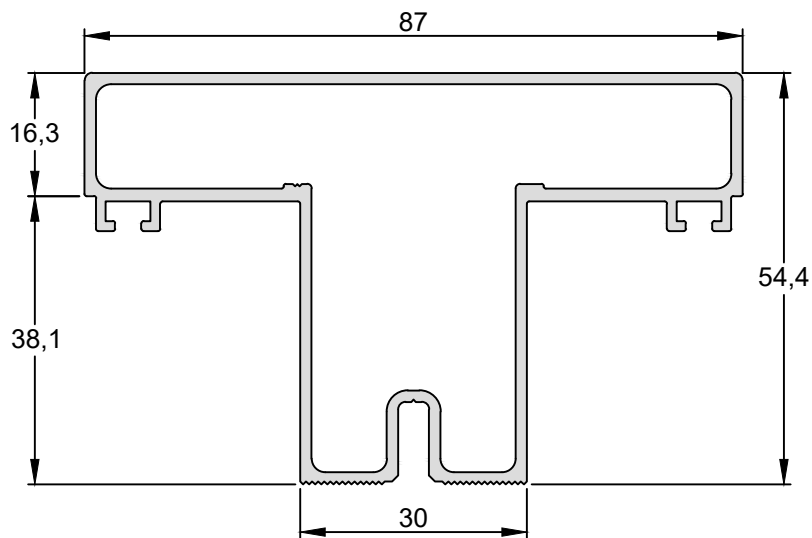

SISTEMA DE FACHADAS  ITAPEMA



Boletim Técnico

Novo Perfil

Luva da Coluna "AD-354"

AD-356 1,445 kg/m

Luva da Coluna "AD-354"

AD-356 1,445 kg/m

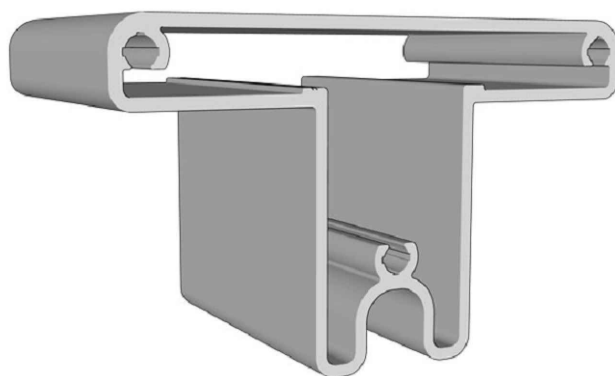
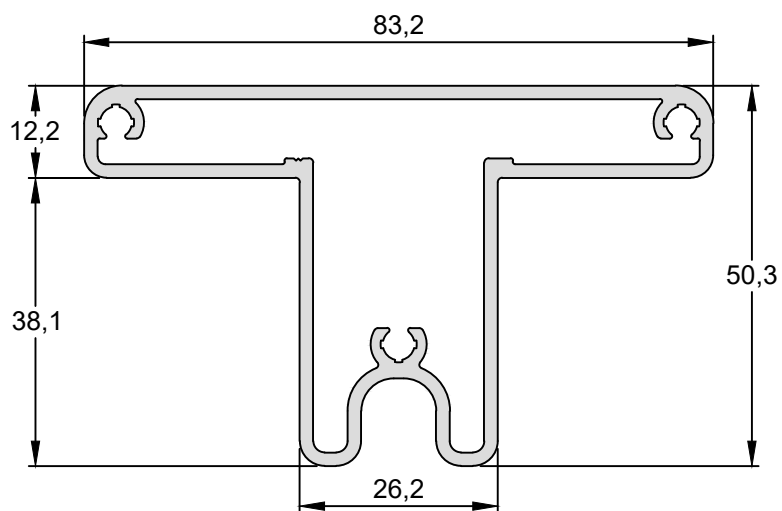

SISTEMA DE FACHADAS ITAPEMA



Boletim Técnico

Novo Perfil

Marco para Coluna
AD-355 1,130 kg/m

Marco para Coluna
AD-355 1,130 kg/m

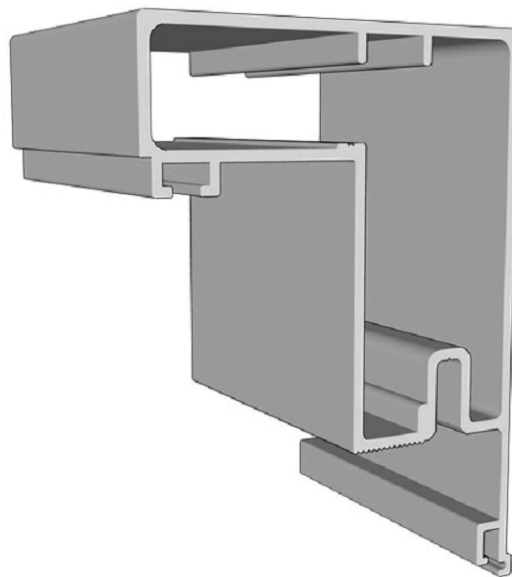
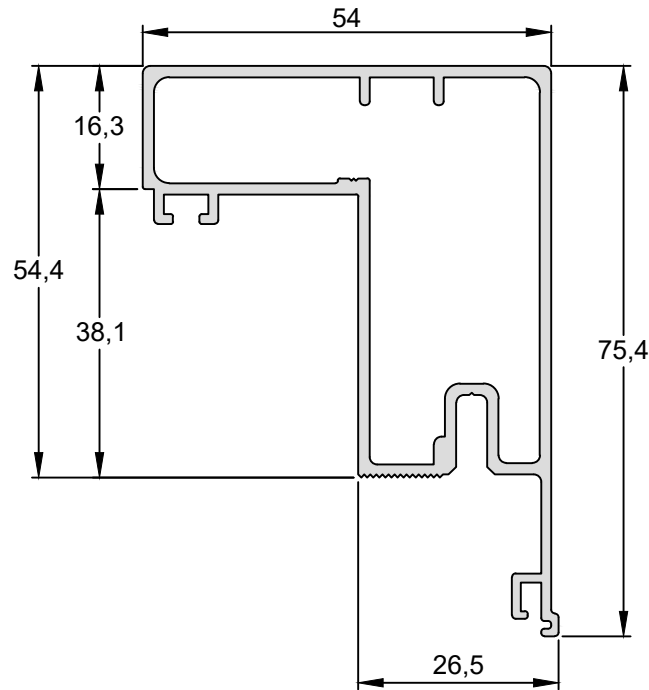

SISTEMA DE FACHADAS ITAPEMA



Boletim Técnico

Novo Perfil

Coluna 90°

AD-361 1,608 kg/m

Coluna 90°

AD-361 1,608 kg/m

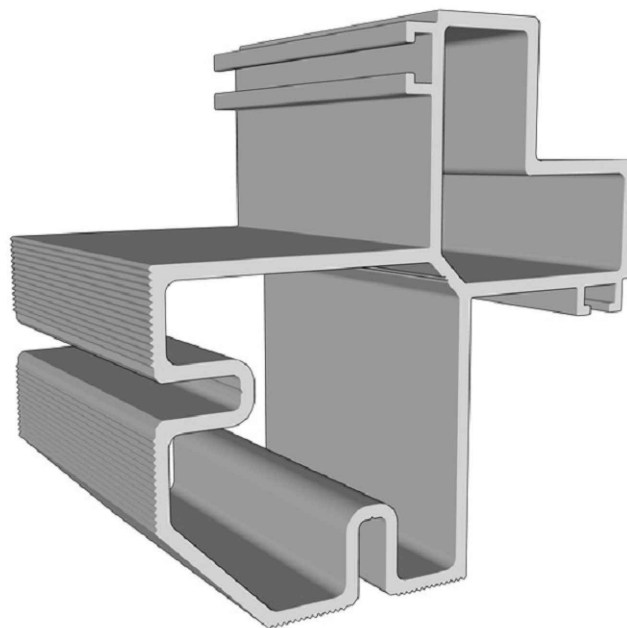
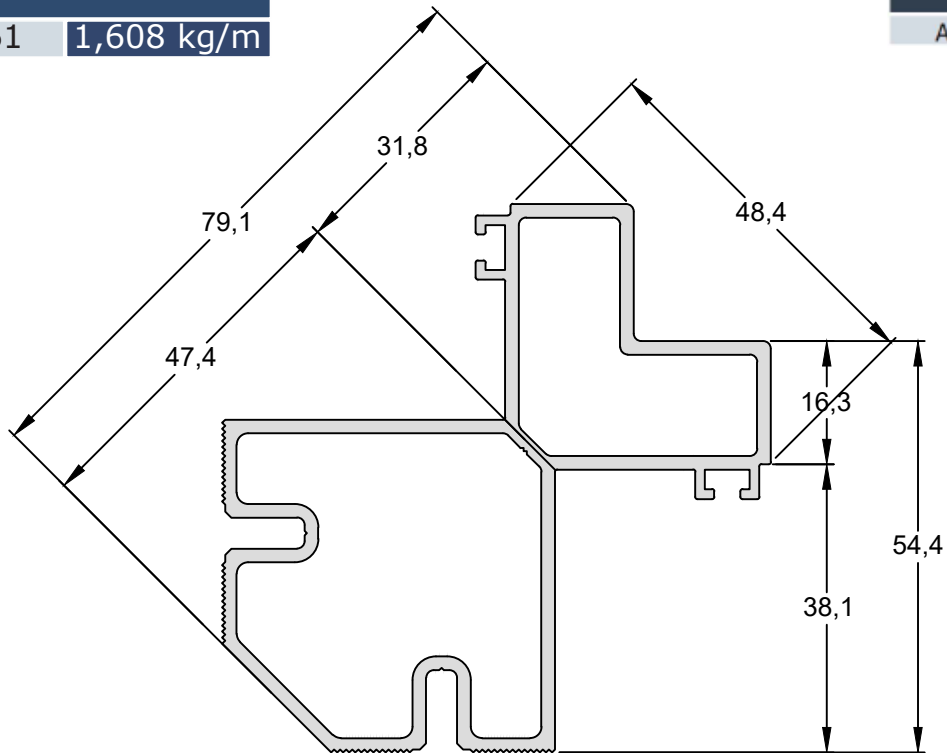

SISTEMA DE FACHADAS ITAPEMA



Boletim Técnico

Novo Perfil

Luva Coluna "AD-400"

AD-401 1,715 kg/m

Luva da Coluna "AD-400"

AD-401 1,715 kg/m

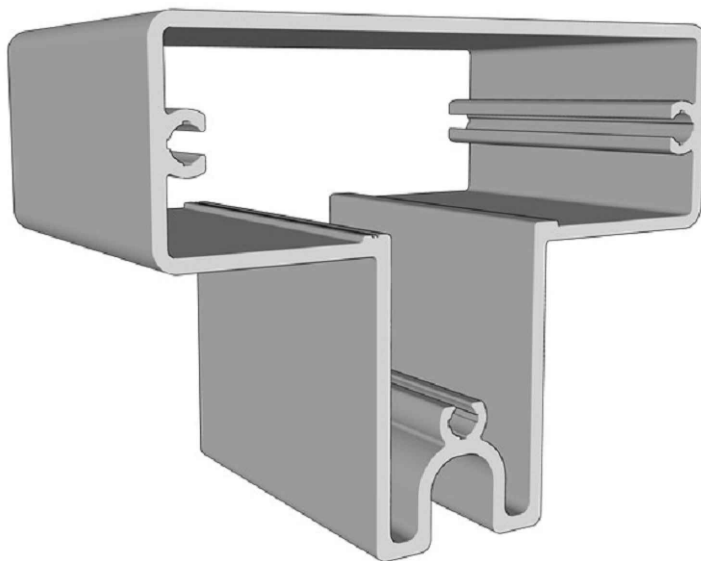
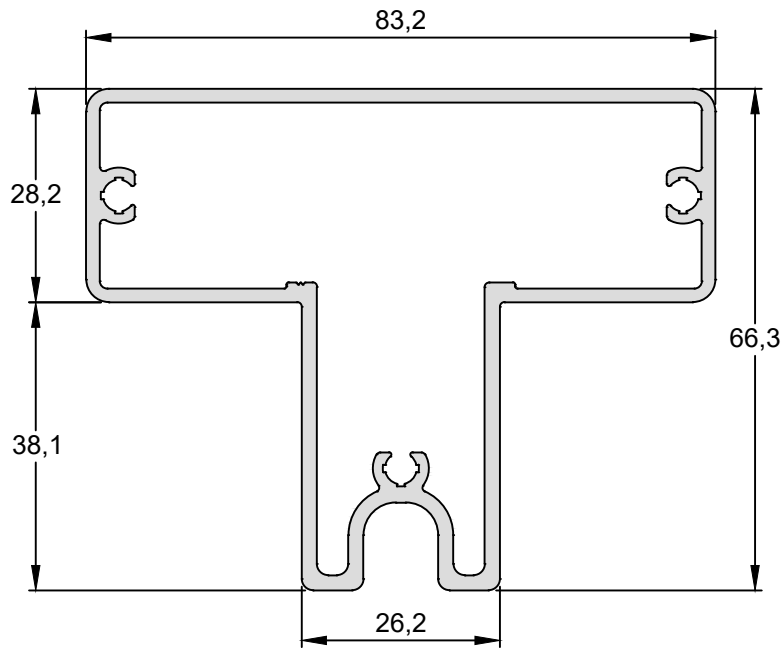

SISTEMA DE FACHADAS  ITAPEMA



Boletim Técnico

Novo Perfil

Luva do Marco "AD-209"
AD-264 1,165 kg/m

Luva do Marco "AD-209"
AD-264 1,165 kg/m

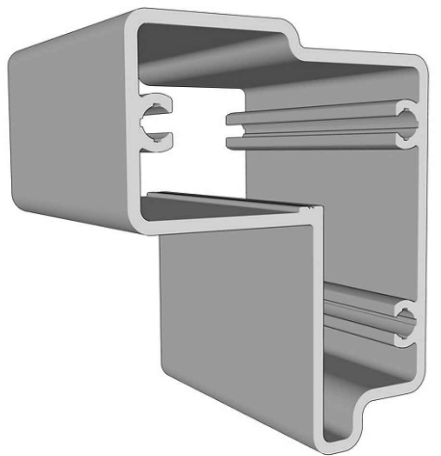
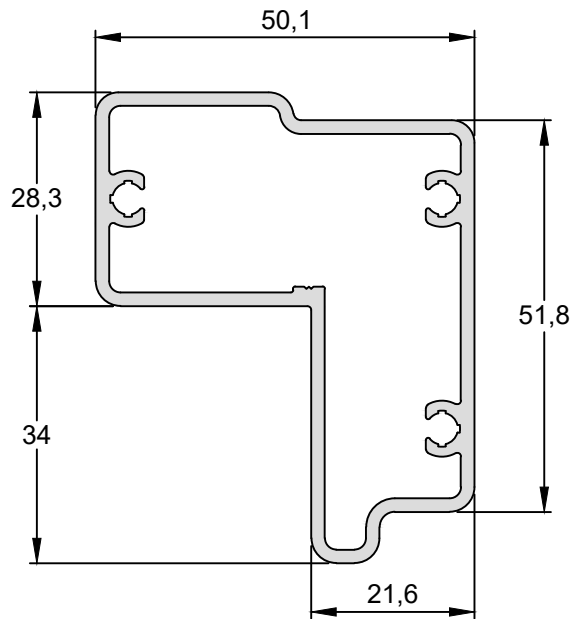

SISTEMA DE FACHADAS ITAPEMA



Boletim Técnico

Novo Perfil

Coluna 90°
AD-344 2,014 kg/m

Coluna 90°
AD-344 2,014 kg/m

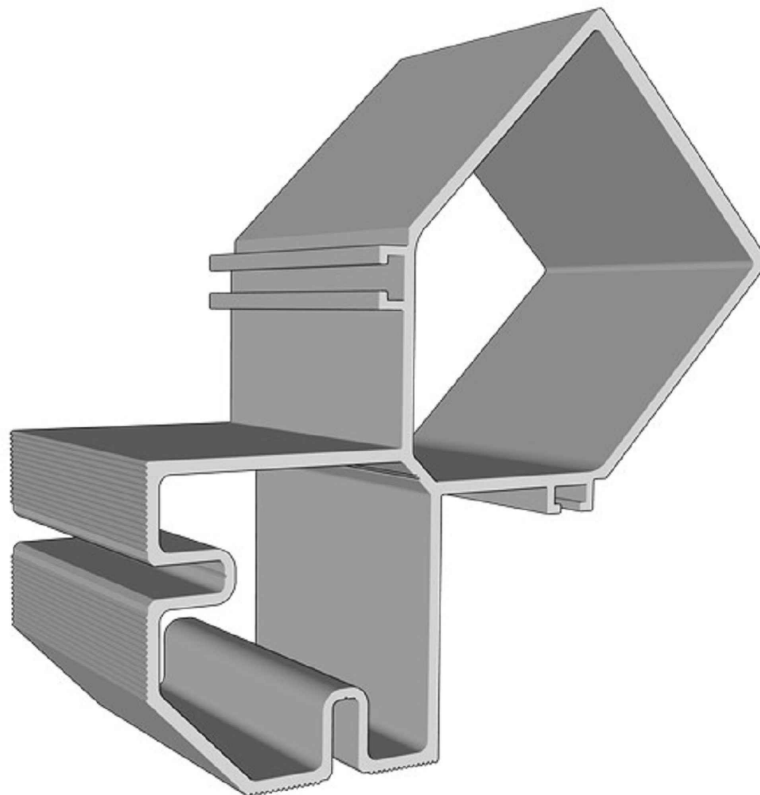
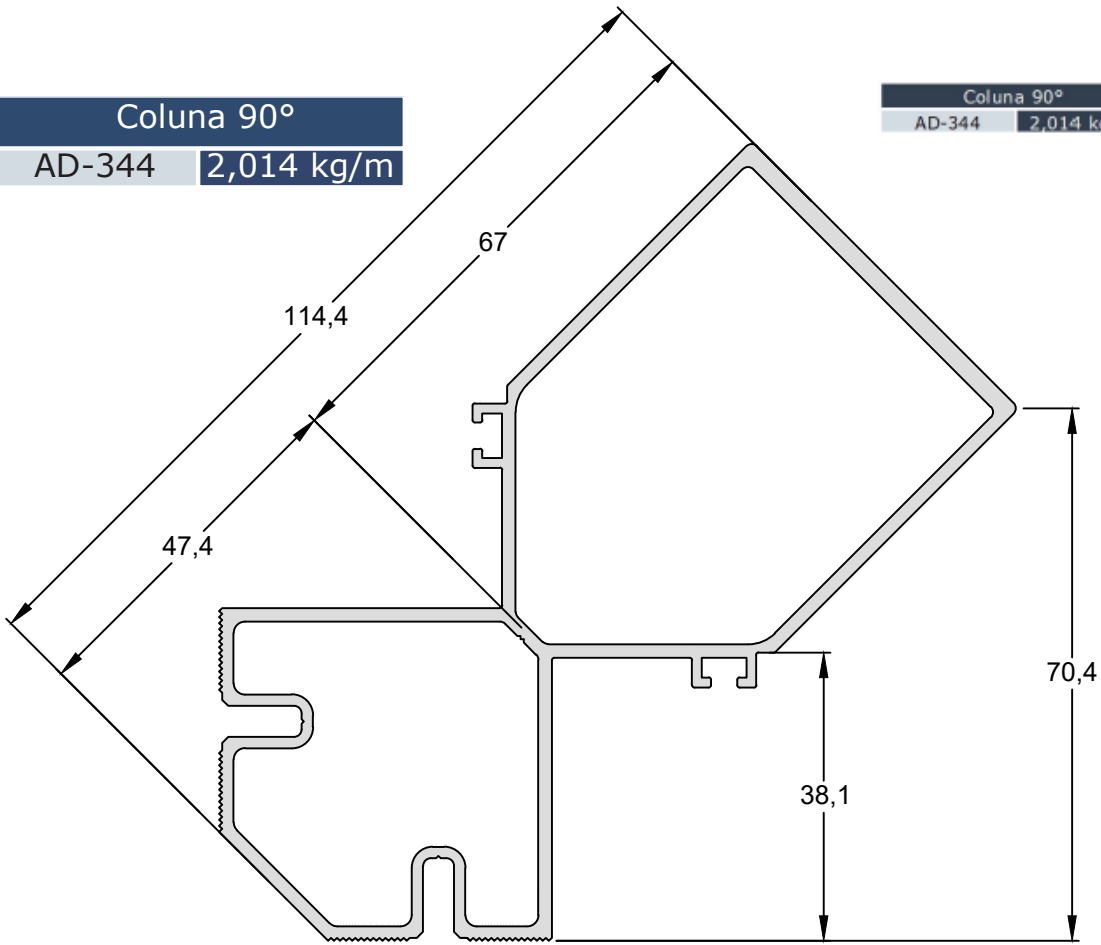

SISTEMA DE FACHADAS  ITAPEMA





Boletim Técnico

Novo Perfil

Luva da Coluna "AD-390"

AD-391 2,615 kg/m

CONSULTAR COMERCIAL

Luva da Coluna "AD-390"

AD-391 2,615 kg/m

CONSULTAR COMERCIAL

SISTEMA DE FACHADAS ITAPEMA

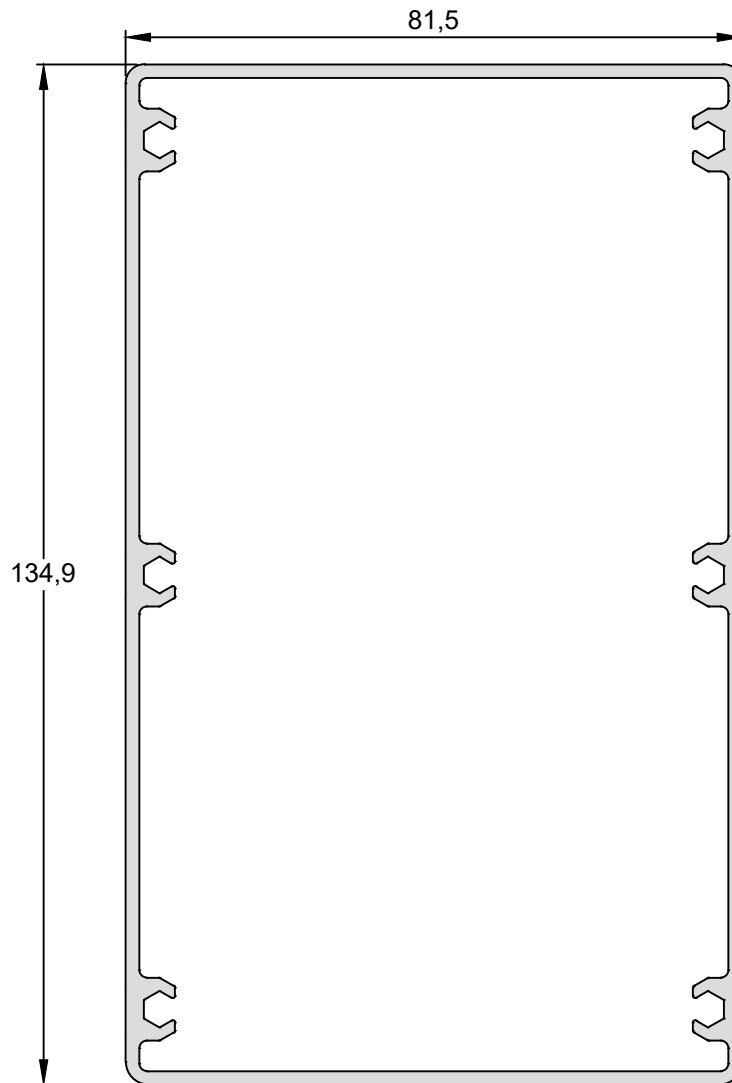



Boletim Técnico

Novo Perfil

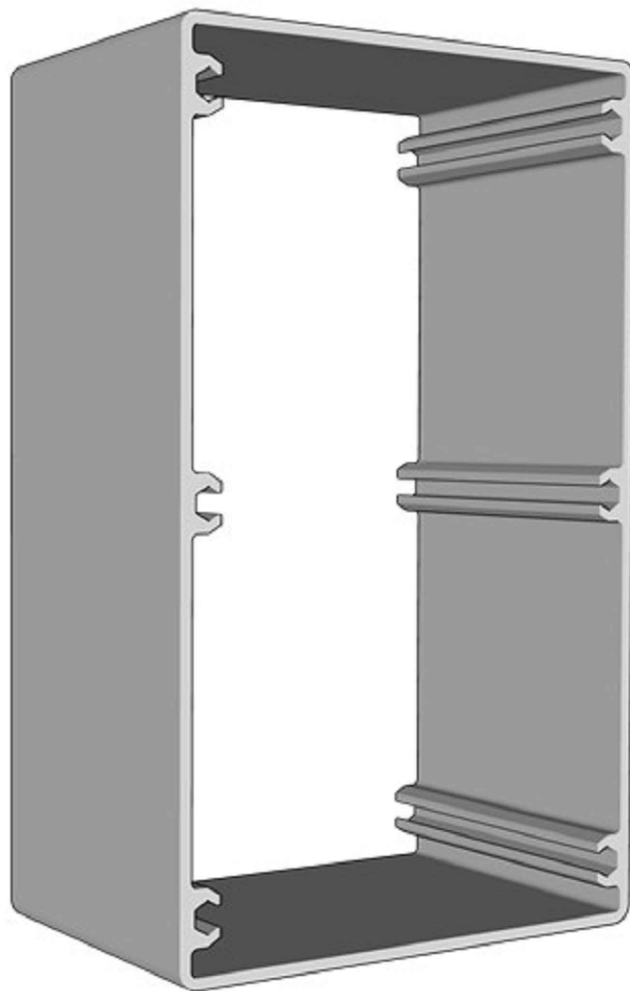

SISTEMA DE FACHADAS  ITAPEMA



Boletim Técnico

Novo Perfil

Marco para Coluna

AD-591 3,328 kg/m

CONSULTAR COMERCIAL

Marco para Coluna

AD-591 3,328 kg/m

CONSULTAR COMERCIAL

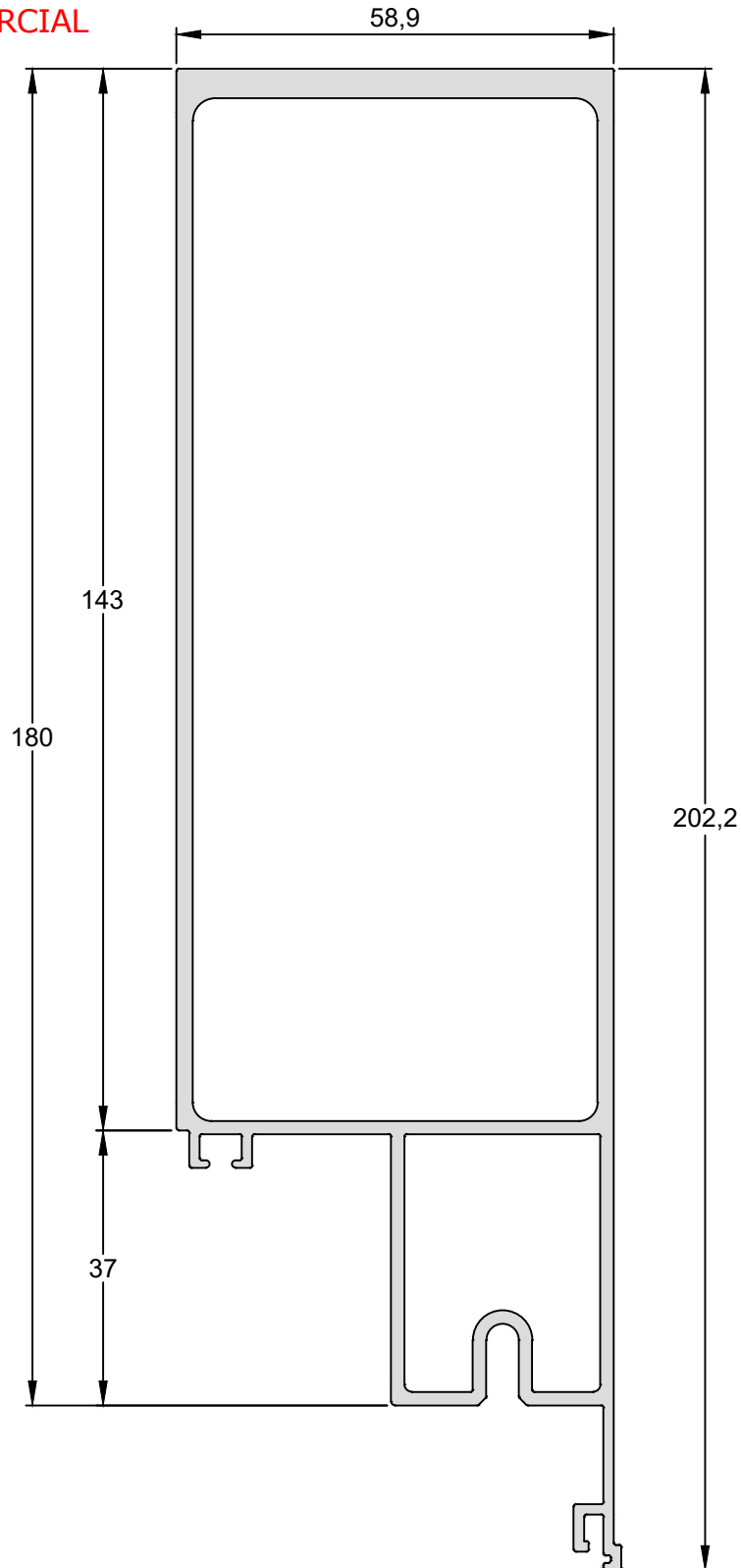

SISTEMA DE FACHADAS ITAPEMA



Boletim Técnico

Novo Perfil

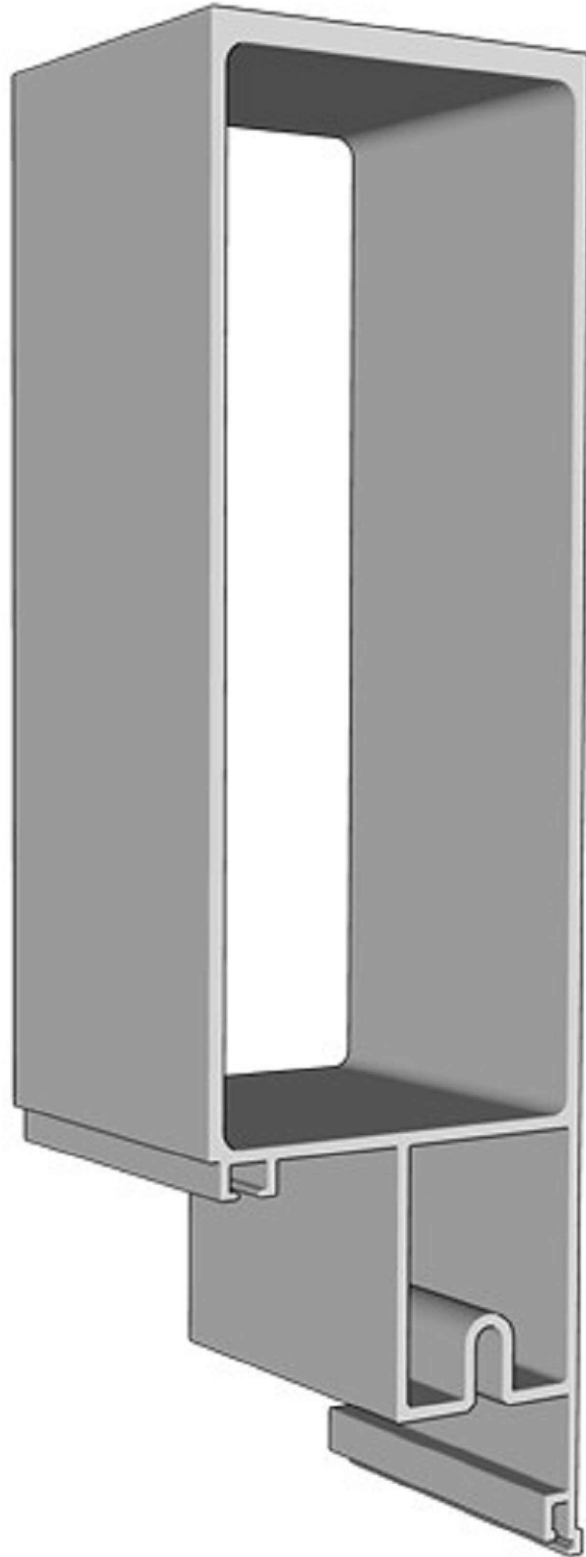

SISTEMA DE FACHADAS  ITAPEMA



Boletim Técnico

Novo Perfil

Luva Marco Tubular "AD-591"
AD-392 2,085 kg/m

Luva Marco Tubular "AD-591"
AD-392 2,085 kg/m

SISTEMA DE FACHADAS ITAPEMA

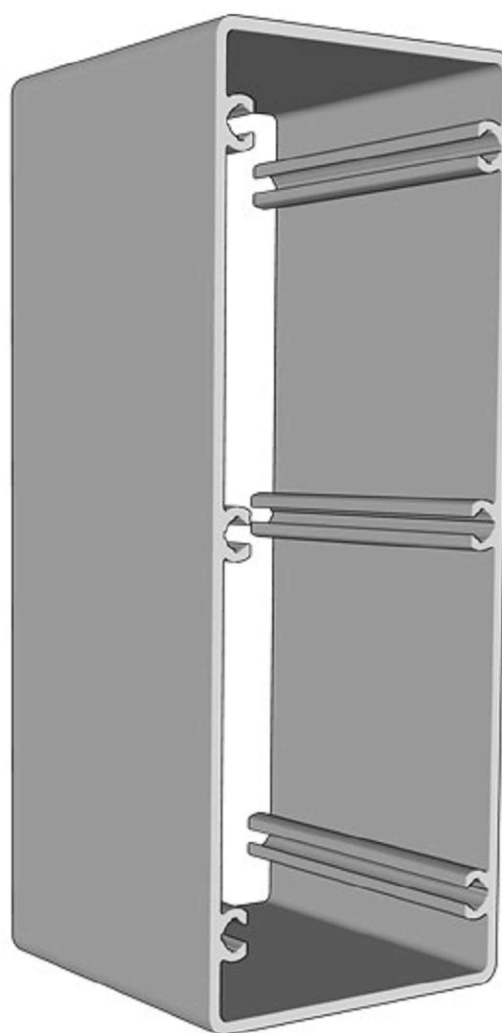
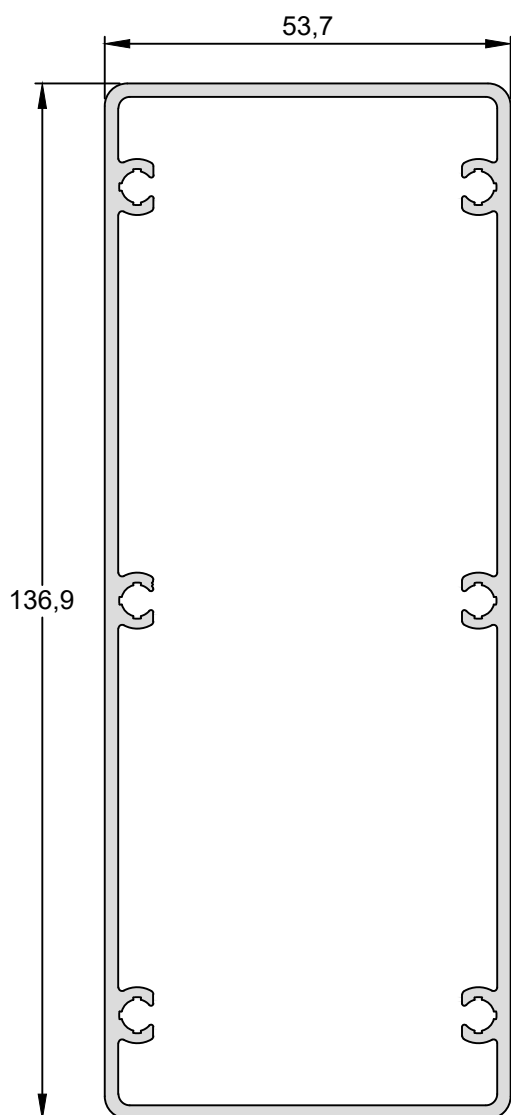



Boletim Técnico

Novo Perfil

Perfil para Ancoragem 90°

AD-270 1,779 kg/m

Perfil para Ancoragem 90°

AD-270 1,779 kg/m

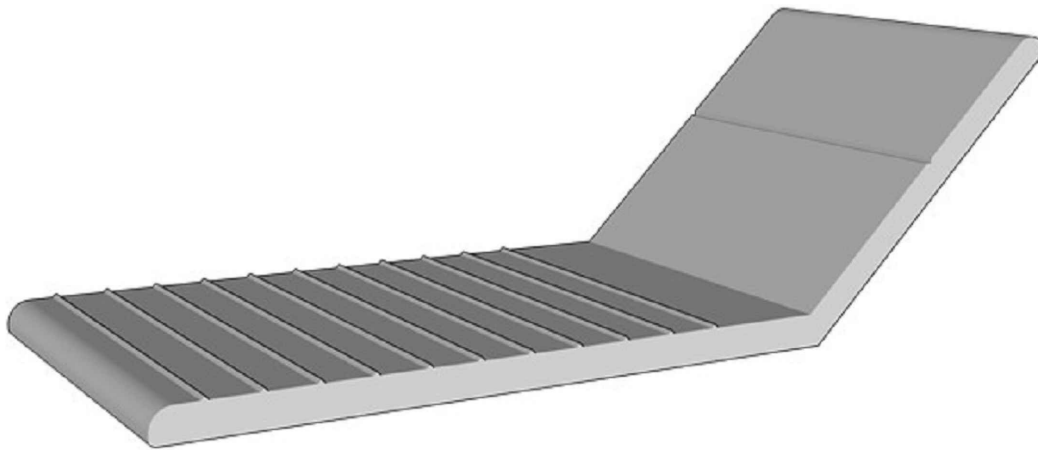
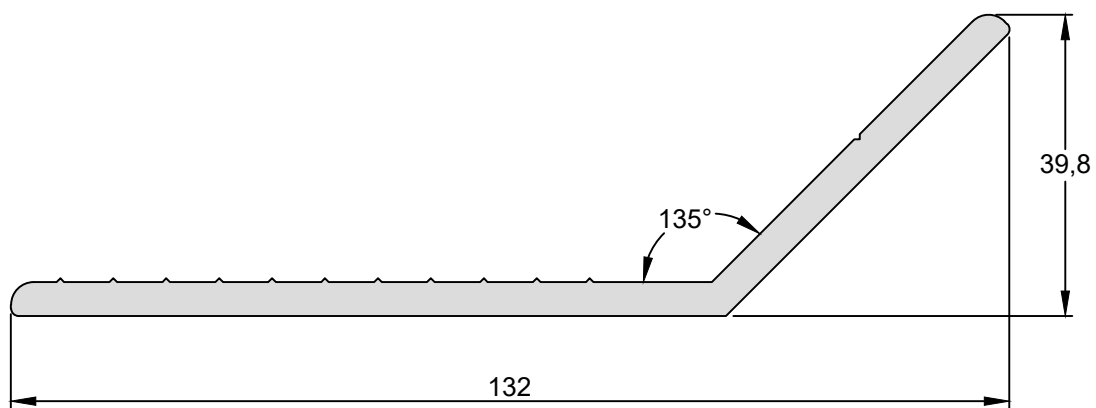

SISTEMA DE FACHADAS  ITAPEMA



Boletim Técnico

Alteração de Perfil

SISTEMA DE FACHADAS ITAPEMA

ANTIGO

Coluna Central
AD-200 1,811 kg/m

Coluna Central
AD-200 1,811 kg/m

ANTIGO



Coluna Central
AD-200 1,898 kg/m

NOVO

Coluna Central
AD-200 1,898 kg/m

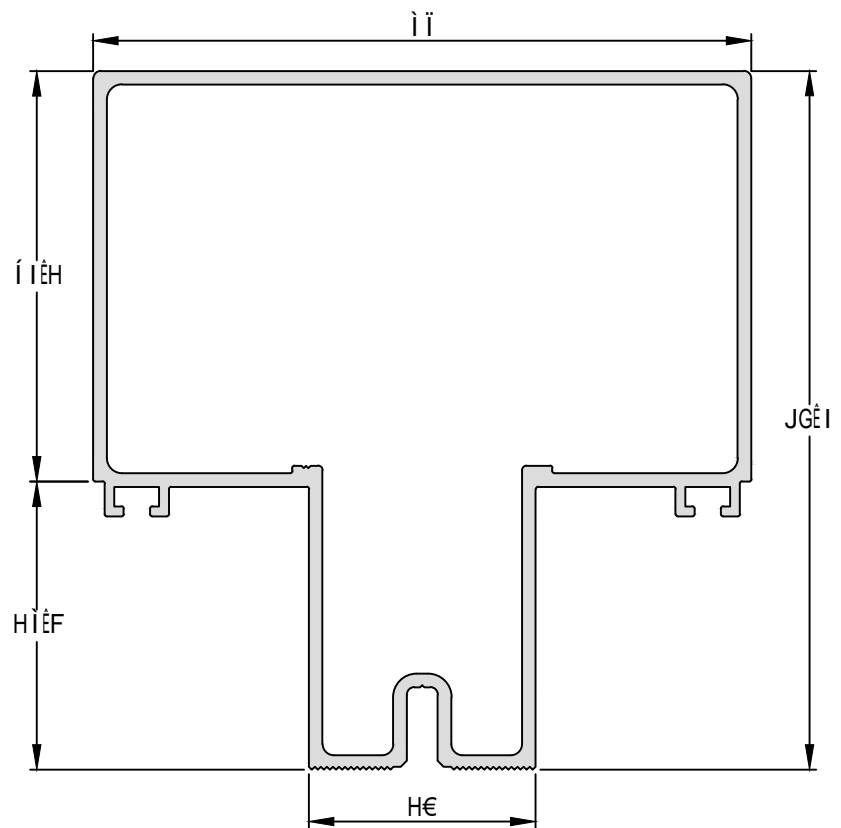
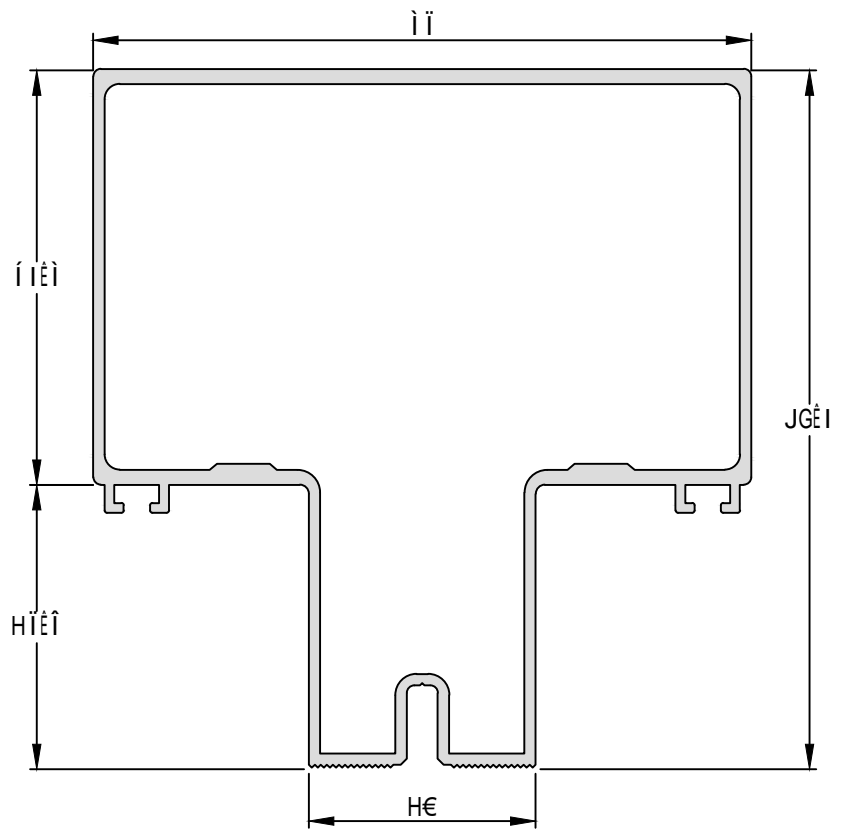



Boletim Técnico

Alteração de Perfil

Luva da Coluna "AD-200"
AD-212 2,007 kg/m

ANTIGO



Luva da Coluna "AD-200"
AD-212 2,040 kg/m

NOVO

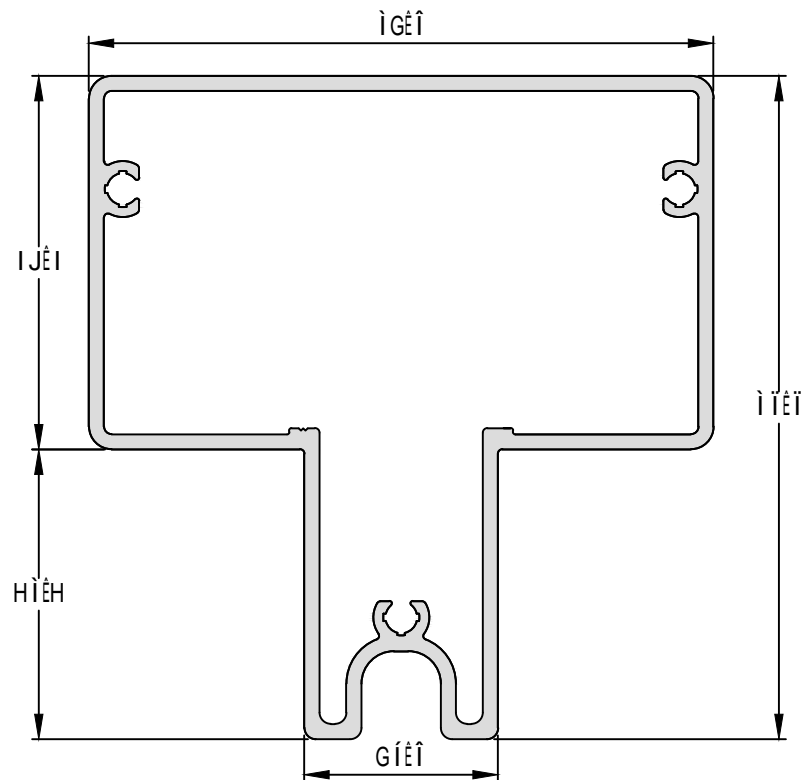
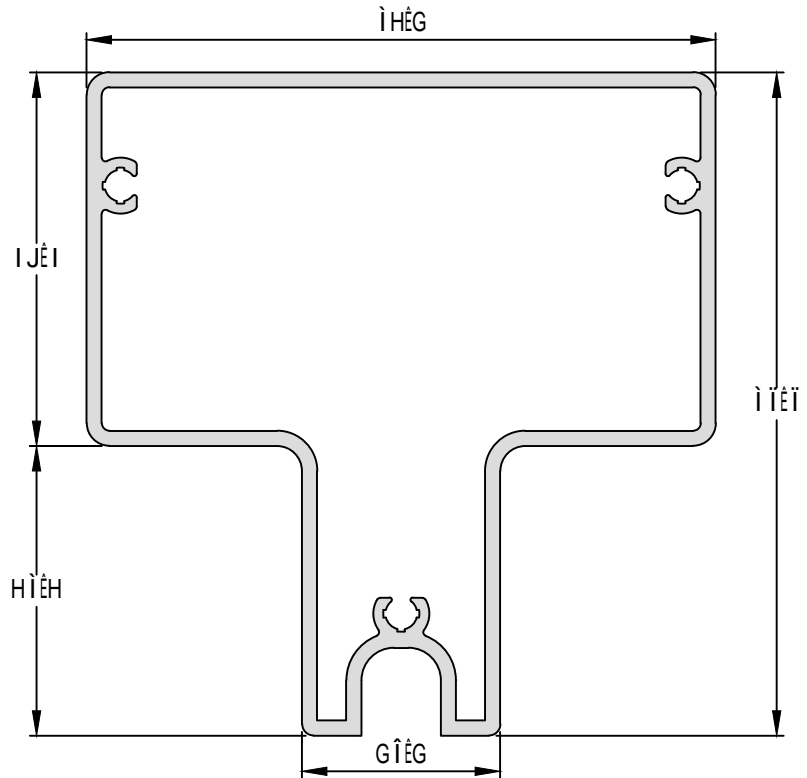

SISTEMA DE FACHADAS  ITAPEMA



Boletim Técnico

Alteração de Perfil

Travessa Intermediária	
AD-203	0,832 kg/m

ANTIGO

Travessa Intermediária	
AD-203	0,831 kg/m

NOVO



Boletim Técnico

Alteração de Perfil

ANTIGO

Trilho Superior -
Vidro 08mm

LT-001 0,601 kg/m

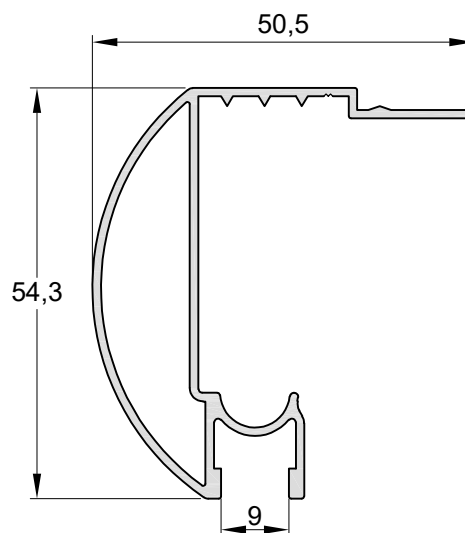

NOVO

Trilho Superior -
Vidro 08mm

LT-001 0,603 kg/m

